

FloorBed[®]
by Accora



FloorBed 2 Siderails

IFU-FL2-003 EN REV 04

Accora

Contents

Title	Page
Welcome	2
General warnings	3
1. Means of delivery	3
2. Safety Instructions	3
3. Intended use	3
4. Technical specification	4
5. Accessories and spare parts	4
6. Assembly and fitting	4
7. Using the siderails	8
8. Functionality check	10
9. Cleaning and disinfection	10
10. Troubleshooting	10
11. Storage	10
12. Guarantee	11
13. Disposal	11
14. Daily inspection	11
15. General maintenance	11
16. Table of symbols	11
17. Contact Details	11

The FloorBed 2 Siderails are classified as a Class 1 Medical Device in accordance with the Medical Devices Regulation 2002 as amended and the Medical Device Regulation 2017/745.



Notice to User

If a serious incident occurs in relation to this medical device, affecting the user or the patient, then the user or patient should report the serious incident to the medical device manufacturer (or distributor) and, in the European Union, the user should also report the serious incident to the Competent Authority in the member state where they are located.



Accora Ltd, 38 Main Street,
Swords, Co. Dublin, Ireland, K67 E0A2
T: +353 (0)1 695 0614

Welcome

Dear Customer,

Thank you for purchasing an Accora healthcare product. Before operating the bed, you must read and understand all the instructions in this manual. All actions and handling of the bed must be performed in accordance with the instructions in this manual.

Please ensure that the manual is available to users and operators throughout the bed's service life.

If you need further information, please contact us. See section 17 for region specific contact details.

This instruction manual applies to the FloorBed 2 Siderails.

The FloorBed 2 Siderails are designed to be used by patients who have a FloorBed 2.

Before operating with this accessory, you must read and fully understand this Instruction Manual. All actions and handling of the FloorBed 2 Siderails must be performed in accordance with the instructions in this Instruction Manual.

Any actions that are inconsistent with this Instruction Manual are performed at your own risk and Accora shall not be liable for any injury or damage. Please ensure that this Instruction Manual is available to Users, Carers, Operators and Patients throughout the life of the FloorBed 2 Siderails.

The FloorBed 2 Siderails should be regularly checked by the User, Carer, Operator or Patient to ensure the setup is correct and functioning as intended.

Design Policy and Copyright

® And ™ are trademarks belonging to Accora Ltd unless otherwise stated. As our policy is one of continuous improvement, we reserve the right to modify designs without prior notice. © Accora Ltd 2020.

GENERAL WARNINGS

1. Keep this Instruction Manual available for future reference.
2. These instructions must be observed to ensure the safe and effective use of FloorBed 2 Siderails and the safety of users and carers.
3. FloorBed 2 Siderails must be assembled, positioned and used in accordance with these instructions.
4. FloorBed 2 Siderails must not be exposed to smoke, naked flame, extreme temperature, flammable gases or other hazardous substances or situations.
5. Accora shall not be held liable for any damage, injuries or accidents arising from unauthorised modifications, non-genuine spare parts, negligence or use that is at variance with this manual which can result in serious injury or death.
6. Only use siderails, and other accessories, that are compatible with this bed as supplied by Accora. Incompatible siderails can create serious hazards.
7. Keep children and pets away from this bed unless supervised by an adult as there is a risk of injury and/or choking on small parts.
8. When routing cables for other electronic equipment used with the bed (e.g. air mattress pump), ensure cables cannot be squeezed, crushed or damaged by the moving parts on the bed e.g. siderails.
9. Never sit, stand or hang on the siderails.
10. Assembly and fitting MUST be carried out by suitably trained and qualified personnel.
11. Do not modify the FloorBed 2 Siderails.
12. Patients, or users, should be risk assessed to ensure they are able to understand this manual and to operate FloorBed 2 Siderails safely without risk to themselves or others.
13. If the combined weight of the mattress and accessories exceeds 35kg, the maximum patient weight of the bed must be reduced accordingly.
14. Do not attach anything to the siderail, e.g. mattress air pump.
15. Do not install the side rails when a user is in the bed. The user must be transferred out of the bed before fitting the side rails
16. Siderails must not be used for restraint of a patient. Patients should be risk assessed by a qualified clinician.
17. Where a speciality mattress or mattress overlay is used and the distance from the top of the uncompressed mattress to the top of the siderail, if fitted, is less than 220mm/8.7in a risk assessment must be performed to assure equivalent safety.

1. Means of delivery

The FloorBed 2 Siderails are supplied disassembled.

Bars, brackets and fabric require assembly and fitting to a FloorBed 2 nursing bed.

An inspection must take place upon receipt to ensure the delivery is complete and undamaged.

Any missing parts, faults or damage must be reported immediately to the carrier, and Accora, in writing.

When moving the FloorBed 2 Siderails, loading or unloading, care must be taken so that no parts are lost or damaged.

2. Safety Instructions

1. Assembly and fitting MUST be carried out by suitably trained and qualified personnel.
2. Before using the FloorBed 2 Siderails, you must read this Instruction Manual and use this device in accordance with it.
3. The FloorBed 2 Siderails MUST not be used if faults have been detected that may injure the patient, staff or a third person, or damage the FloorBed 2, FloorBed 2 Siderails or the surroundings.
4. Before using the FloorBed 2 Siderails, the operator MUST understand the siderails and their functionality.
5. The FloorBed 2 Siderails must never be overloaded.
6. When operating the FloorBed 2 Siderails, or any other moving parts of the bed, care must be taken to ensure that the patient, other people and objects do not become trapped.
7. When repairing the FloorBed 2 Siderails, only original materials and components supplied by Accora may be used.
8. FloorBed 2 Siderails should be inspected daily.
9. FloorBed 2 Siderails should only be fitted following a clinical assessment of the user or patient.

3. Intended Use

The FloorBed 2 Siderails may only be used with FloorBed 2 & FloorBed 2 Junior.

Subject to a risk assessment, side rails can help to create a safer environment for the bed user.

4. Technical Specification

Environmental information:

Condition	Temperature Range	Relative Humidity	Atmospheric pressure
Operating	+10°C to +40°C +50°F to +104°F	30% to 75%	700 hPa to 1060 hPa
Transport/ storage	-20°C to +50°C -4°F to +122°F	(Non- condensing)	

If the FloorBed 2 Siderails are stored in conditions outside the normal operating range, they should be allowed time to stabilise, in normal operating conditions, before use.

Description	Value
External Dimensions	2000 L x 500 H x 50 W mm (Standard version) 2200 L x 500 H x 50 W mm (Extended version)
Max Load allowed for FloorBed 2 Siderails	75kg
Material	PU Fabric and mild steel
Total weight of Siderail set	16.8kg
Expected service life	5 years

The FloorBed 2 Siderails are available in two lengths and are supplied as a kit comprising two/three items.

Part Number / Description	Kit includes
SDR-0-FL2-100 2000mm Standard Siderail kit Suitable for adult patients of height above 146cm	SDRBR-0-FL2-200 + FABKIT-0-CB1-000 OR SDRBR-0-FL2-200 + SDRFAB-0-FL1-100 + SDRMET-0-FL1-100
SDREX-0-FL2-100 2200mm Extended Siderail kit Suitable for adult patients of height above 146cm	SDRBR-0-FL2-200 + FABEXKIT-0-CB1-000 OR SDRBR-0-FL2-200 + SDRFABEX-0-FL1-100 + SDRMETEX-0-FL1-100
SDR-0-FL4-500 2000mm Standard Siderail kit with bolster Suitable for child patients of height between 75cm and 155cm, only when fitted to FloorBed 2 Junior: NSB-0-FL2-200 + Head and Footboard Bumpers BMHNE-0-FL4-500 + Safety Sleeve SLE-0-FL4-100 + Protection Plate PROPL-0-FL4-500	SDRBR-0-FL4-500 + FABKIT-0-FL4-000 OR SDBR-0-FL4-500 + SDRFAB-0-FL4-100 + SDRMET-0-FL1-100

5. Accessories and spare parts

Description	Order code
FloorBed mattress infill	MTINF-0-FL1-000
Siderail fitting bracket set (fits 2000 and 2200mm)	SDRBR-0-FL2-200
Siderail fitting bracket set for siderail with bolster	SDRBR-0-FL4-500
2000mm Fabric and bars set	FABKIT-0-CB1-000
2200mm Fabric and bars set	FABEXKIT-0-CB1-000
2000mm Fabric with bolster and bars set	FABKIT-0-FL4-000
2000mm Fabric set	SDRFAB-0-FL1-100
2200mm Fabric set	SDRFABEX-0-FL1-100
2000mm Fabric set with bolster	SDRFAB-0-FL4-100
2000mm Bars set	SDRMET-0-FL1-100
2200mm Bars set	SDRMETEX-0-FL1-100
Siderail bracket fixing kit	SDRKIT1-0-FL1-000
Siderail fabric fixing kit	SDRKIT2-0-FL1-000
Siderail pull strap	SDRPLST-0-FL1-000

6. Assembly and fitting

WARNING

Assembly **MUST** be carried out by suitably trained and qualified personnel.

All functions **MUST** be tested and approved after assembly by suitably trained and qualified personnel.



Assembly **MUST** take place in a clear, uncluttered area and children and pets should be kept away.

Do not install the side rails when a user is in the bed. The user must be transferred out of the bed before fitting the side rails.

Where a speciality mattress or mattress overlay is used and the distance from the top of the uncompressed mattress to the top of the siderail, if fitted, is less than 220mm/8.7in a risk assessment must be performed to assure equivalent safety.

1. Check whether any visible damage has occurred to the bed during transport and that the delivery is complete.
2. You will need the following tools to assemble and fit the FloorBed 2 Siderails:
 - a. 4mm Allen key
 - b. 5mm Allen key

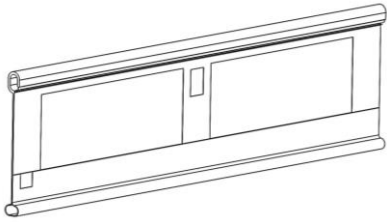
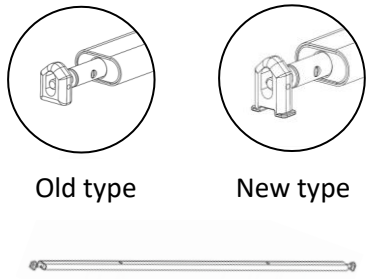
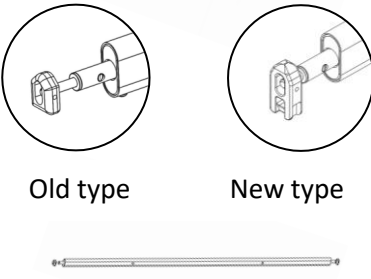
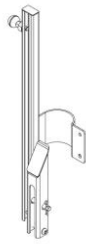
3. Identify all components:

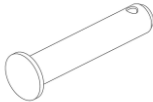
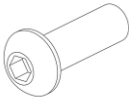
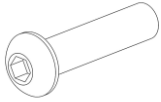
<p>Fabric Cover Quantity 2</p>	
<p>Bottom Bar Quantity 2</p> <p>There are two types of block. Either may be shown in this manual</p>	
<p>Top Bar Quantity 2</p> <p>There are two types of block. Either may be shown in this manual</p>	
<p>Siderail Bracket Quantity 4</p>	
<p>Lifting Handle Quantity 4</p>	
<p>R-Clip Quantity 4</p>	
<p>Pin (50mm) Quantity 4</p>	
<p>Bottom Bar Fixing Screw (25mm) Quantity 4</p>	
<p>Bracket Fixing Screw (35mm) Quantity 4</p>	

Note - Throughout this user manual, the left side and right side of the bed are described from the viewpoint of a patient lying in the bed.

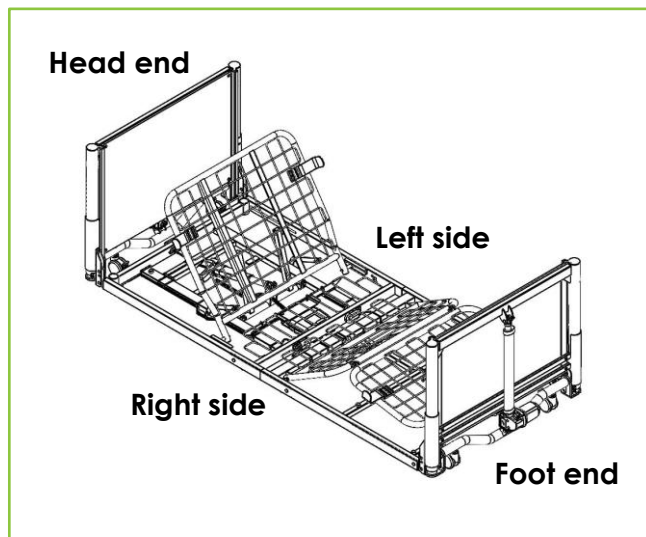

Note - The following instructions describe fitting a siderail bracket to the left side of the bed at the head end.

4. Remove siderail bracket fixing bolts and washers from the cross-bar using a 4mm Allen key and retain for reuse.

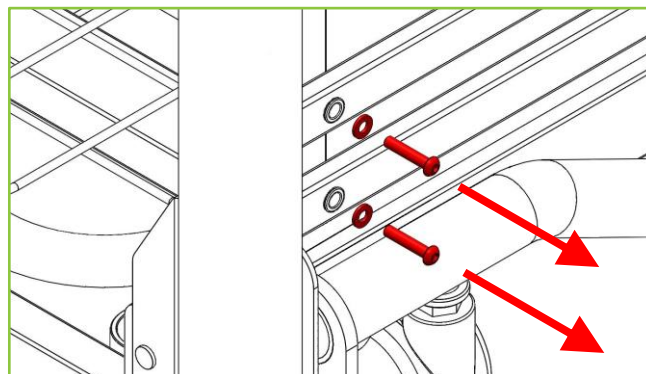
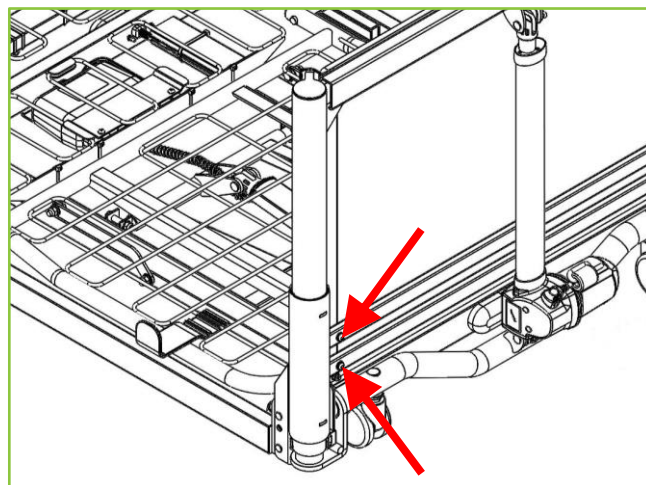

5. Remove the mattress platform locking pin and R-clip.

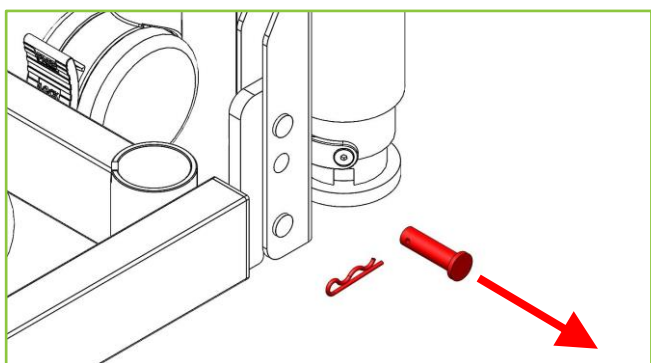
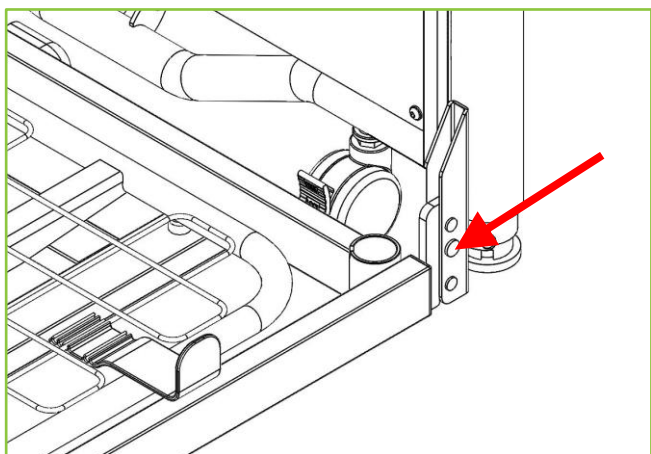

Note – This pin will not be needed to fit the siderails. Store safely for use should the siderails be removed.

6. Remove the two screws and locking pin and R-clip from the siderail bracket.
7. Fit the bracket from the top, and slide downwards into position.

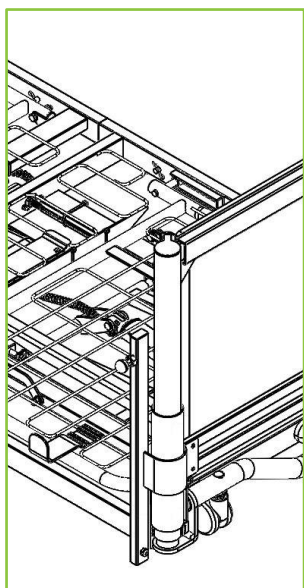
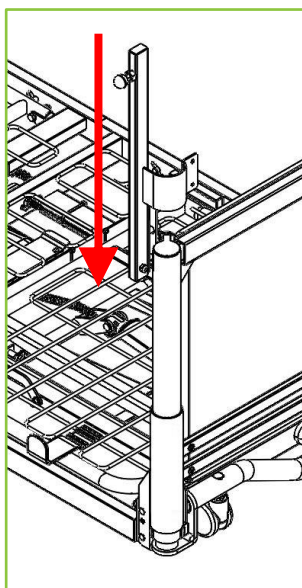

8. Align the siderail locking pin hole and the mattress platform locking pin hole.

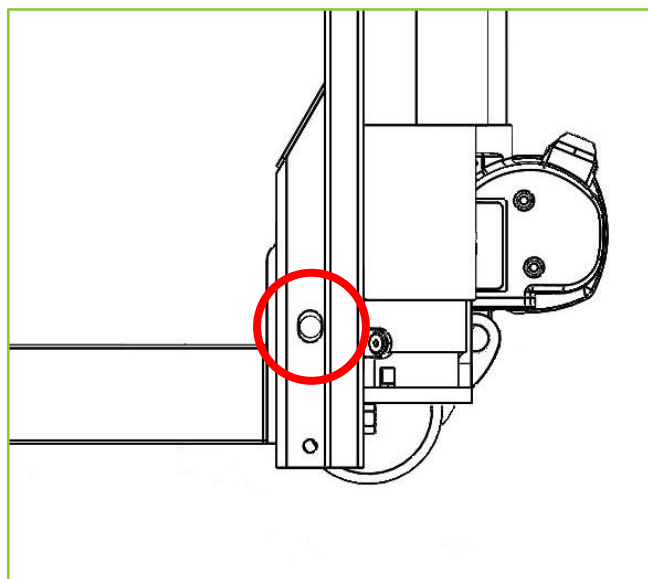

9. Fit the locking pin and R-clip. (50mm Long, supplied with the siderails).

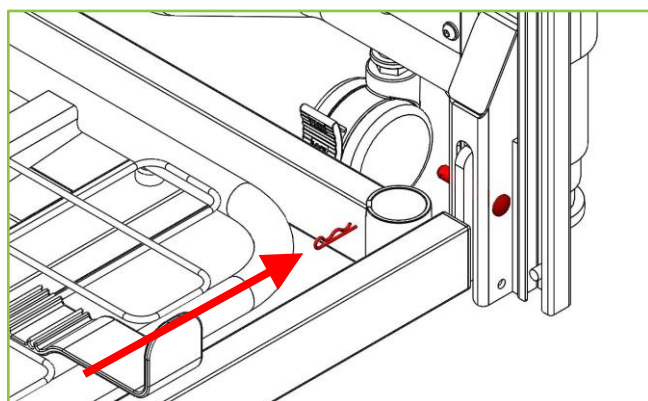
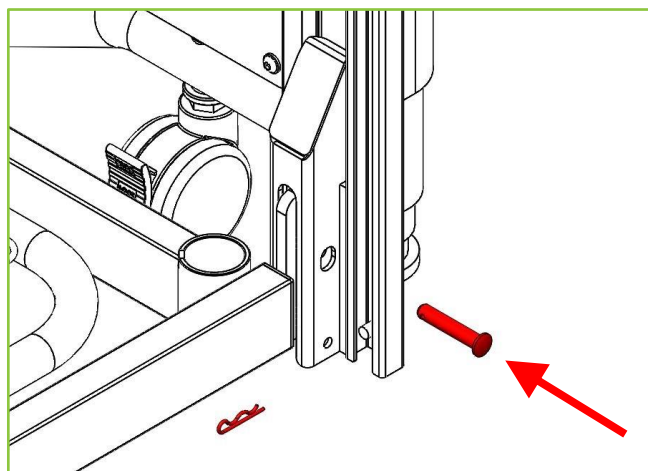

- Fit the Bracket Fixing Screw (35mm long) using a 5mm Allen key.

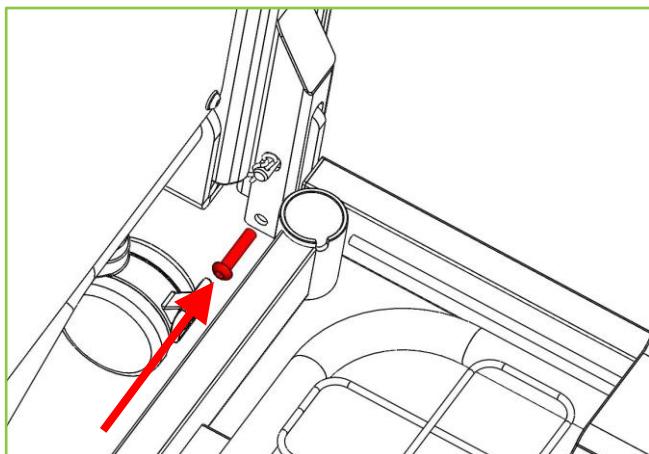

- Align the holes of the curved part of the bracket with the holes in the cross-bar.

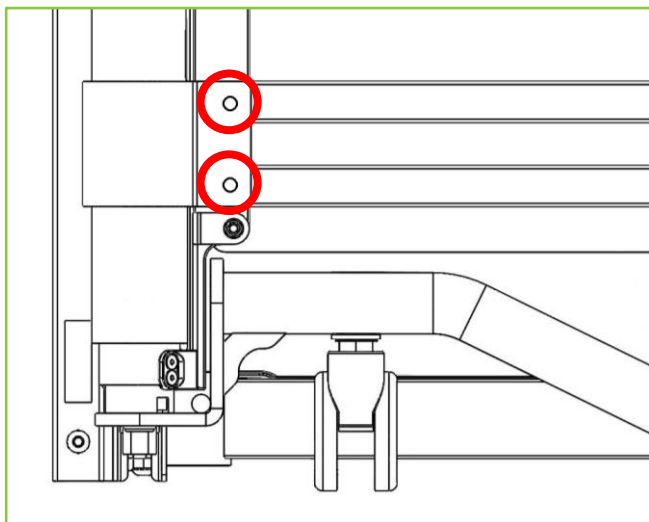

- Fix the curved part of the bracket to the cross-bar using a 4mm Allen key and the bolts and washers removed in step 4

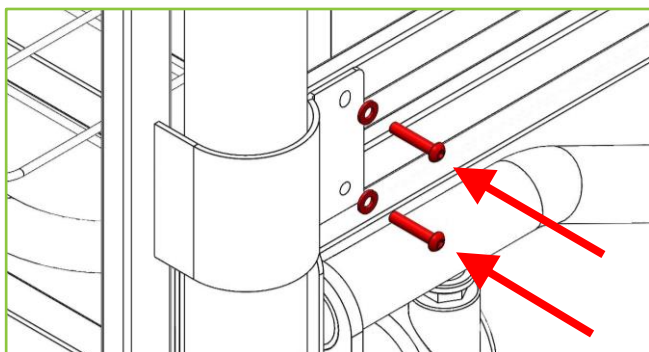

- This bracket is now in place. Repeat the above process to fit a siderail bracket to the right side of the bed at the foot end.

- Remove one of the Fabric Covers of the siderail from its packaging and spread it out on a flat surface with the labels facing up. ('Top and Outside' label facing up.)

- Zip up the top flap of the fabric cover and insert the top bar.

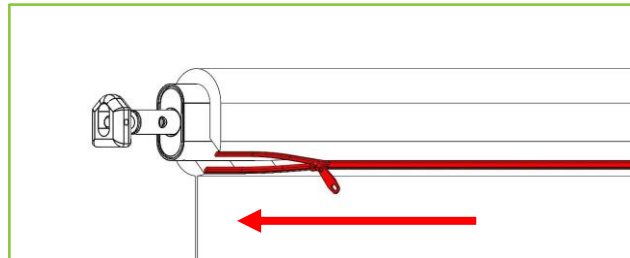

Note – the top and bottom bars are different and can be identified as shown in paragraph 3 of section 6.

- Insert the bottom bar through the slot at the bottom of the Fabric Cover.

- Fit the lifting handles to both ends of the top bar. Feed the straps through the slots in the top of the fabric cover.

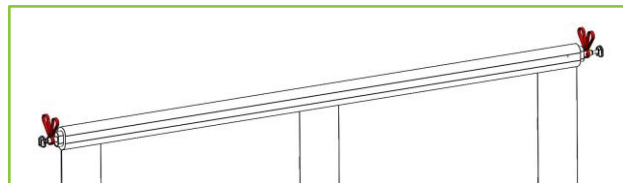
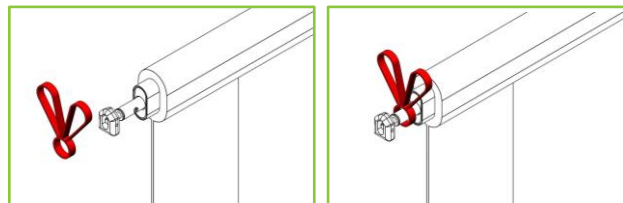

- Using the hand set, raise the FloorBed at least 20cm from the ground.

- Insert the top bar up into the bottom of the sliding track at both ends of the siderail.

Note – 'Top and Outside' label MUST be on the top and outside i.e. facing away from the bed. The integral bolster on SDR-0-FL4-500 must be on the inside of the bed.

Note – Orientation of top bar as shown below with the angled end of the sliding block facing upwards.

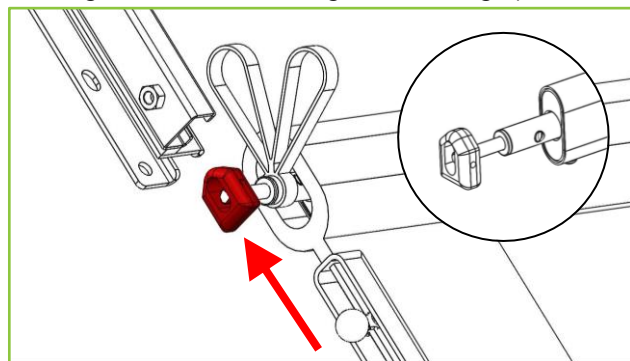

20. **Important!** Ensure **ALL** the plastic guides are fitted into the sliding track. (4 Plastic guides each end of siderail fabric.)

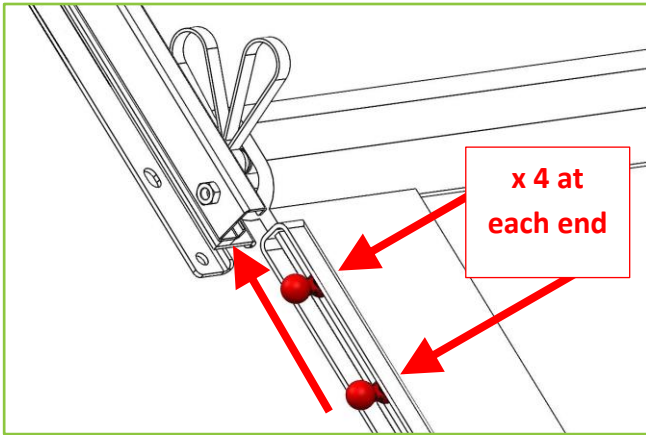

Note – Siderail SDR-0-FL4-500 has an additional locking plunger at the base of the support. Pull this plunger out in order to move the bars up the sliding track.

21. Insert the bottom bar into the sliding track at both ends of the side rail.

Note – Orientation of bottom bar as shown below with the angled end of the sliding block facing upwards.

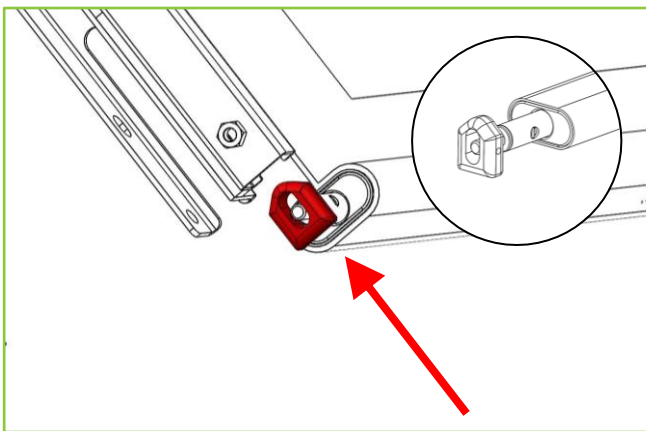

22. Fit the Bottom Bar Fixing Screw (25mm long) using a 5mm Allen key.

Note – the Bottom Bar Fixing Screw (25mm long) **MUST** be fitted into the sliding block to secure the bottom bar in place.

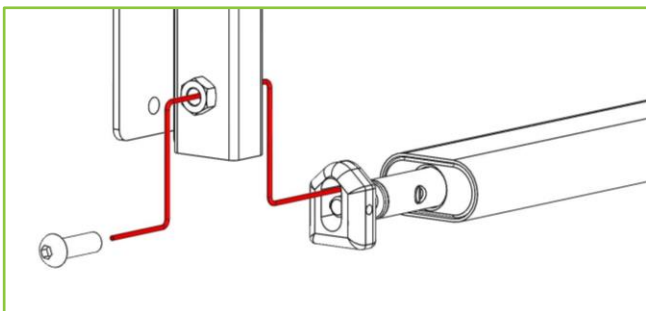

Note – once the bottom bar fixing screw has been fitted, make sure the bottom bar cannot move up or down.

23. The siderail is now fitted to one side of the bed.

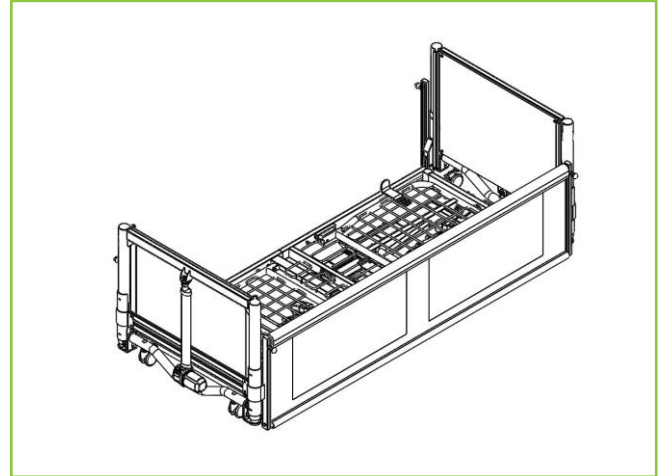

24. Repeat the process for assembling the siderail on the other side of the bed.

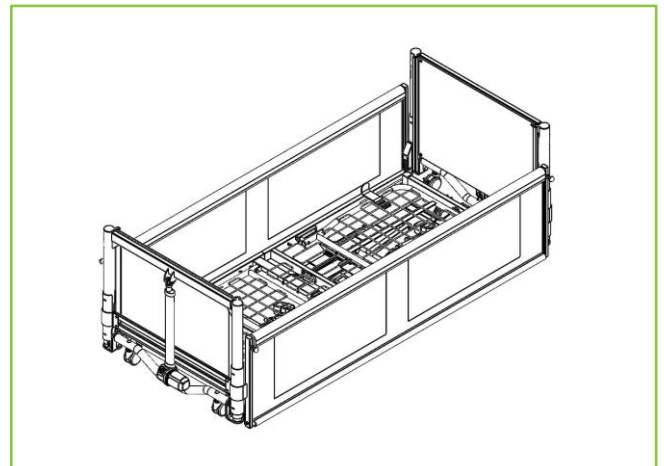

7. Using the siderails

WARNING

Patients, or users, should be risk assessed to ensure they are able to understand this manual and to operate FloorBed Siderails safely without risk to themselves or others.

Siderail must always be in the up position when the patient or user is alone or unattended unless a clinical evaluation has been carried out and indicates otherwise.

Never sit, stand or hang on the siderails.

Do not attach anything to the siderail, e.g. mattress air pump.

Note: Where recommended by a patient risk assessment, FloorBed mattress infill pieces may be used when siderails are fitted (except SDR-0-FL4-500 where the bolster is part of the siderail). Siderails must be raised and lowered one end, or one 'corner', of the bed at time.

To raise the siderail:

1. Use the lifting handle to raise the siderail. If SDR-0-FL4-500 is fitted, pull out the bottom plunger first to release the top bar.

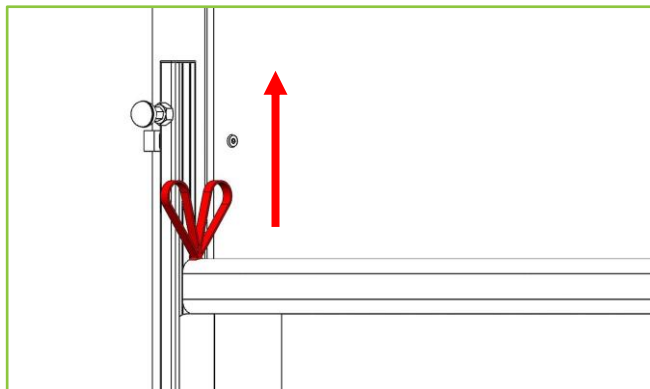

2. Secure the top bar in place using the locking plunger. (You may wish to retract the plunger, raise the side rail and then release the plunger to lock the siderail in the raised position)

1. Retract the locking plunger
2. Raise the siderail
3. Release the locking plunger

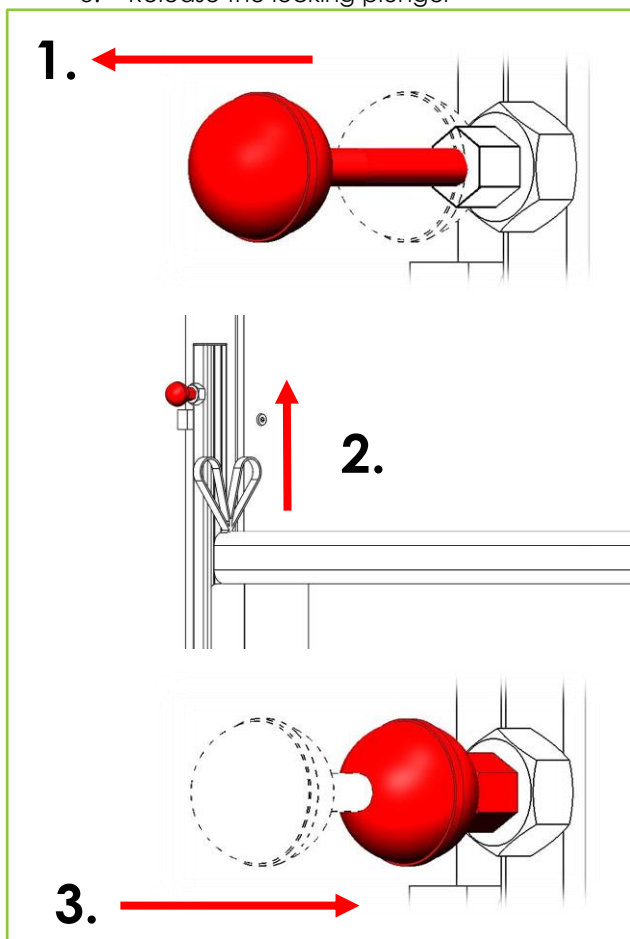

3. Ensure the siderail is properly raised and latched by pushing down gently.

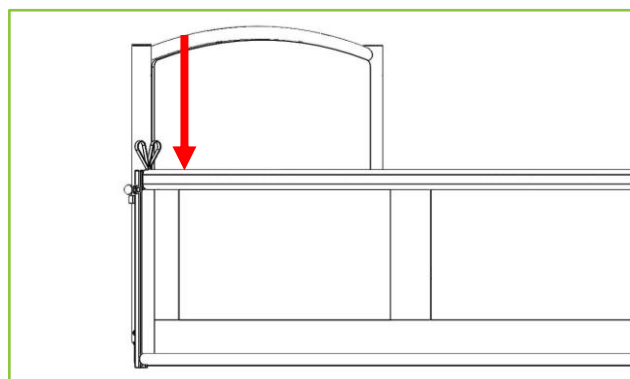

To lower the siderail:

1. Pull firmly upwards on the lifting handle.

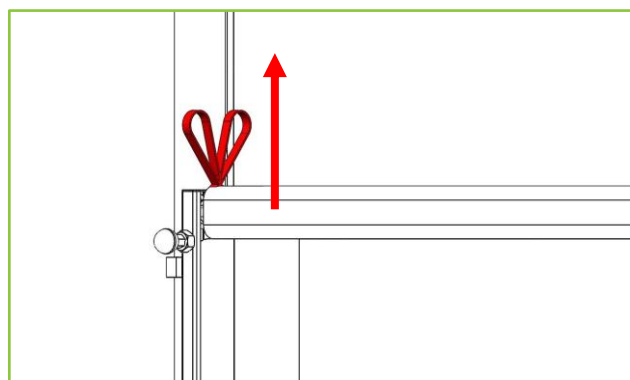

2. Retract the locking plunger.

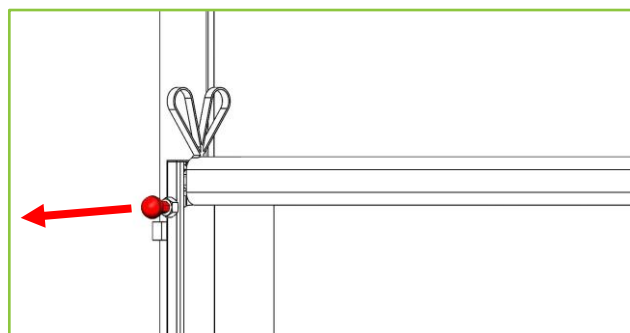

3. Lower the side rail.

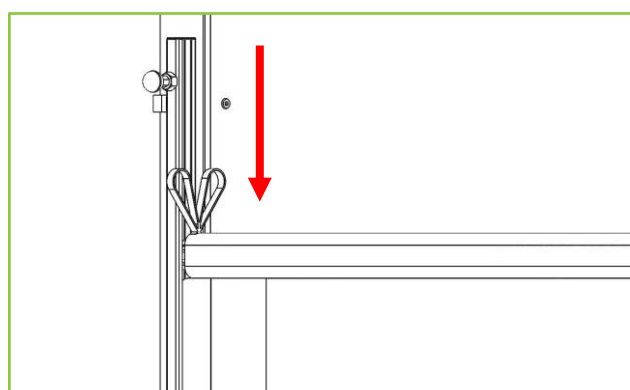

4. Make sure the siderail is fully down and top bar is below the top of the mattress at both ends. If SDR-0-FL4-500 is fitted, ensure the top bar is located properly by the bottom plunger. You may need to pull the plunger out, then push the siderail bar down and into the plunger.

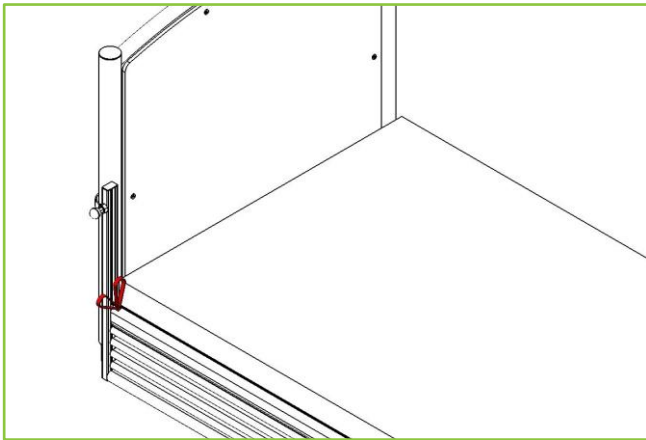

8. Functionality check

WARNING

All functions **MUST** be tested and approved after assembly by suitably trained and qualified personnel.

Raise the FloorBed Siderails using the Lifting Handle and secure the top bars in place using the locking plungers on each corner of the bed.

Check the following:

1. Does the FloorBed 2 Siderail operate as per its intended purpose without unexpected noise or motion?
2. Are there any gaps or breaks in the fabric, loose or broken threads or stitching?
3. Are all fixtures and fittings tight and secure?
4. Does the FloorBed 2 Siderail frame appear stable and secure?
5. Are all electrical cables (including accessories, e.g. mattress air pump) secured and routed to prevent damage?
6. Are all the plastic glides fitted in the siderail track?
7. Is the lower bar secure and unable to move up or down?
8. Is the siderail fabric position correctly as per Section 6?
9. Are the zips fully closed?
10. Are lifting handles are fitted to each end of each FloorBed Siderail?
11. Are all parts present and free from damage?
12. Is each side rail bracket is secured to the outside of the head/foot board with a bolt and nut and to the mattress platform with a bolt and pin with R-clip?
13. Are the locking plungers secure and functioning correctly?
14. Are all fixtures, fittings, nuts, bolts etc. tight and secure as appropriate?
15. Is the frame mechanically sound, with no signs of damaged welds or cracked paint?
16. Are any parts of the frame bent or out of shape?
17. Are the FloorBed Siderails correctly positioned on the bed frame?
18. Where a speciality mattress or mattress overlay is used and the distance from the top of the uncompressed mattress to the top of the siderail, if fitted, is less than 220mm/8.7in a risk assessment must be performed to assure equivalent safety.

If any damage, performance issue, or cause for concern is noted during this inspection, the FloorBed Siderails and/or FloorBed should be withdrawn from service and appropriate steps should be taken.

9. Cleaning & Disinfection

Do not attempt to clean the FloorBed 2 Siderails when fitted to a bed. Remove the siderails from the bed and place them in a safe cleaning environment.

To disinfect the FloorBed 2 Siderails, only use detergents designed for use in healthcare. Do not use abrasives, scourers or other materials that could damage the coating. Do not use corrosives, caustics or strong acids.

Do not use detergents that could alter the structure or behaviour of the plastics (petrol etc.). Clean metal structure of the siderails by wiping with a damp and properly wrung cloth.

Accora cannot be liable for any damage or risk of damage if inappropriate cleaning or disinfectant agents are used. Before cleaning the PU material make sure the foam that is enclosed in the siderail fabric cover is removed. Do to this unzip the top bar, and then unzip the zip for the foam enclosure.

The P.U. material can be washed up to 40 degrees Celsius on a delicate or hand wash machine programme please see guide below. Do not bleach, tumble dry or iron.



10. Troubleshooting

If any parts are considered faulty, or defective, please contact Accora and order a replacement. Do not attempt to repair any of the components in case of damage or defect.

11. Storage

Store the product unassembled and keep all parts safely together including this Instruction Manual. Wrap or cover all parts with a protective cover to prevent damage. The fabric cover must be washed and left to dry properly before storing. The Fabric Cover may be folded and stored in a plastic cover to protection from humidity and dirt. Do not place heavy or sharp objects on the FloorBed 2 Siderails. Do not store in damp conditions.

12. Guarantee

The warranty period for the FloorBed 2 Siderail is 2 years. If the siderail was acquired for a care home, the care home maintenance department should contact Accora to obtain the necessary parts.

13. Disposal

In the event of the disposal of materials from the Siderails, end-of-life parts must be disposed of in accordance with current environmental regulations.

14. Daily Inspection

Daily visual inspection is strongly recommended and may be carried out by carer, user or other person.













1. Do the FloorBed 2 Siderails operate as per the intended purpose without unexpected noise or motion?
2. Are there any signs of abuse, damage or excessive wear?
3. Are there any gaps or breaks in the fabric, loose or broken threads or stitching?
4. Are all fixtures and fittings tight and secure?
5. Does the FloorBed 2 Siderail frame appear stable and secure?
6. Are all accessories fitted in line with the accessory manufacturer or accessory supplier's instructions?
7. Are all electrical cables (including accessories, e.g. mattress air pump) secure and routed to prevent damage?
8. Is the area around, above and below the bed clear of possible obstruction?
9. Are there any risks of entrapment or patient injury?
10. **Important!** Are all the plastic guides (4 each end of each fabric panel) fitted and running freely in the siderail track?
11. Is the lower bar secure and unable to move up or down?
12. Is the siderail fabric fitted as per labelling (See 'Top and Out Side' label) with the zips on the outside?
13. Are the zips fully closed?
14. Are Lifting Handles are fitted to each end of each FloorBed 2 Siderail Top Bar?

If any damage, performance issue or cause for concern is noted during this inspection the FloorBed 2 Siderails and/or FloorBed should be withdrawn from service and appropriate steps should be taken.

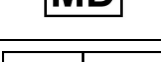
15. General Maintenance

Repairs must be carried out by suitably trained and qualified personnel.

16. Table of symbols

	Warning, beware of potential hazard – refer to instruction for use
	Refer to instructions for use
	Refer to instructions for use
	Complies with the European Medical Device Regulation 2017/745
	Complies with the Medical Devices Regulations 2002 as amended.
	Medical Device in accordance with EU Medical Device Regulation 2017/745
	EC Representative
	Model number
	Lot/batch number
	Manufactured date
	Manufacturer
Top bar 200cm	Top bar 2000mm
Bottom bar 200cm	Bottom bar 2000mm
Top bar 220cm	Top bar 2200mm
Bottom bar 220cm	Bottom bar 2200mm
	Fitting orientation and warning

17. Contact Details

	UK and Rest of World
Address	Accora Ltd. Charter House, Barrington Road Orwell, Cambridge, SG8 5QP
Telephone	+44 (0)1223 206100
Email	info@accora.care
Website	www.accora.care

Accora



Accora
Barrington Road
Orwell
Cambridge
SG8 5QP
United Kingdom

T: +44 (0)1223 206100
info@accora.care
www.accora.care